

SmartBank^{Lite}

Split Charging System

INSTALLATION & OWNERS MANUAL

MERLIN
POWER SYSTEMS

Part Numbers:
19-2050, 19-2051, 19-2054

Version 3.1

1.0 Introduction

Many thanks for your recent purchase of a Merlin SmartBank Lite.

SmartBank Lite is a split charging device designed to manage the bi-directional charging of 2 battery banks.

SmartBank Lite uses the method of split charging known as Battery Combining. Battery Combining is acknowledged by experts as the most efficient, safest and fastest method of recharging multiple battery banks. This method introduces no voltage drop in the system and does not allow over charging of dissimilar size batteries (or which are at different states of charge).. Battery combining is generally accepted by experts as being vastly superior to blocking diodes, FET (or electronic) charge splitters and VSRs.

SmartBank Lite will work for all charge sources on board. Therefore, if you have an engine alternator, solar panel, wind turbine etc, all will be allowed to charge both batteries.

SmartBank Lite also features an Emergency Parallel Switch, which, when pressed, will force SmartBank to close the contactor for the preset time (Hold Delay). This allows engine starting from the auxiliary battery or running auxiliary loads from the engine battery for a short period of time.

Please take the time to fully read and understand this manual.

Your attention is drawn to **CAUTION!** and **WARNING!** statements throughout this manual. **CAUTION!** relates to practices that may result in damage to the SmartBank Lite or your electrical system. **WARNING!** relates to practices that may result in injury or death.

WARNING! SmartBank Lite is designed for installation by competent engineers. Competent Engineers know and understand work hazards, electrical hazards and safe working practices. Therefore, not all practices that may lead to injury or death are noted within this manual. If you are in anyway unsure about how to safely install this product, pay for a qualified electrical engineer to do it for you.

2.0 Certificate of Conformity

Merlin Equipment Limited T/A Merlin Power Systems of Unit 4, Cabot Business Village, Holyrood Close, Poole, Dorset BH17 7BA. United Kingdom hereby declares that the following product(s):

Merlin SmartBank Lite Part Numbers: 19-2050, 19-2051 & 19-2054 are in conformity with the requirements of the following Directives of the European Union:

EMC Directive 2004/108/EEC & regulation UN/ECE-R10 Rev 4:
EN61000-6-3 2007 EMC – Emission, EN61000-6-1 2007 EMC – Immunity and ISO7637-2 2011 EMC – Vehicles.

James Hortop
Managing Director



3.0 Package Contents

19-2050 Merlin SmartBank Lite – 12V or 19-2051 Merlin SmartBank Lite – 24V:

Merlin SmartBank Lite Central Processing Unit (CPU)
Emergency parallel Switch with integrated warning LED
Split Charge Contactor with bracket

19-2057 Merlin SmartBank Lite – OEM Version (CPU Only):

Merlin Smartbank Lite Central Processing Unit

4.0 Operation

SmartBank Lite continuously monitors two battery banks. When it senses that either battery reaches a preset voltage (connect voltage) for a preset period of time (hold delay), it will close the split charge contactor. When charging ends, the voltage will start to drop. When the voltage reaches a 2nd preset voltage (disconnect voltage) for the preset period of time (hold delay), it will open the contactor.

If the Emergency Parallel Switch is pressed, SmartBank Lite will hold the contactor closed for the same period as the Hold Delay is set for.

It should be noted that the SmartBank Lite stays active whenever power is connected to it. Therefore, power consumption is highly important. SmartBank Lite draws less than 5mA while in standby mode – this equates to 0.84 amp hours per week.

Therefore, it is suitable for systems with low power chargers (eg solar systems). When the contactor is closed, the power consumption rises. SmartBank also features PWM (Pulse Width Modulation) control of the contactor, when enabled this substantially reduces the 'Split Charge Engaged' Power Consumption figure.

Because SmartBank Lite stays active and is independent of the engine or any other charge source, some knowledge of its operation is useful to the user. For example, when the engine is run and then shut down, SmartBank Lite may keep the split charge contactor connected for some time. This is because the system voltage has not yet dropped below the disconnect voltage for the preset time period (hold delay).

Because you can alter the connect/disconnect voltage and timer (hold delay), SmartBank may be configured to perfectly match your system. For example: **Set the Connect Voltage High:** When the engine is started, the split charge will take a while to engage. This gives an engine alternator a period of time to priority charge the engine battery first. This is useful for when engine batteries are small in comparison to auxiliaries or when the engine alternator is undersized. **Set the Disconnect Voltage Low:** This will allow the split charge contactor to stay engaged for longer. When charging finishes, you will pull power from both the engine and auxiliary battery – effectively cross supplementing the auxiliary battery with some of the engine battery's reserve capacity. This is useful when auxiliary batteries are slightly undersized for a given application.

The default setting (presets in the central position) is somewhere between these two extremes.

By setting very short hold delays and very narrow connect/disconnect parameters, you can prevent cross supplementation. This may be useful for when engine batteries are very small (eg a micro engine start battery) and very little reserve battery capacity is available.

There are numerous other scenarios that SmartBank Lite may be set up for. Speak to Merlin Power Systems or your dealer for guidance.

SmartBank Lite also features DSP (Digital Signal Processing). DSP filters the raw voltages that SmartBank Lite reads and averages/smoothes them out – this prevents transient surges, spikes and electrical interference from fooling SmartBank Lite into connecting. DSP is fully automatic. Due to DSP you may notice a slight time lag between the voltage reaching a certain level on your multi-meter and the unit reacting (especially if the change in voltage and rate of change was very large). This is a normal function of the DSP feature.

The LED embedded within the Emergency Parallel Switch also serves as an indicator. When the Split Charge Contactor is engaged (closed), the red LED will light.

5.0 Installation Locations

The SmartBank Lite CPU is not waterproof and should be located in a dry area such as a locker or under the dashboard. The contactor is not waterproof or ignition protected but may be located in damp environments. Note that the contactor has open contacts to facilitate easy cleaning. A sealed IP66 contactor (ignition protected) is available from your local dealer. The emergency parallel switch is IP66 rated and may be located in wet environments.

6.0 Contactor Wiring

6.1 Main Split Charge Cabling

The contactor should be wired between the two battery banks. Ensure that the split charge cables are suitably sized to handle the maximum continuous charging current and maximum current that is likely to run through the contactor when the Emergency Parallel Switch is depressed.

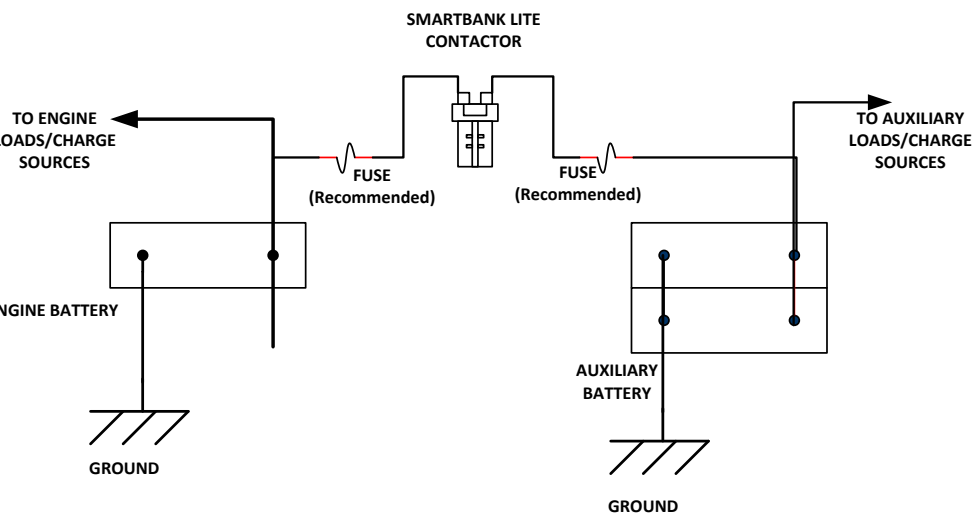

CAUTION & WARNING!: Under sizing the cabling between the batteries and split charge contactor will cause overheating and possible damage to the contactor. Extreme overheating may lead to fire.

We recommend installing two fuses (one each side) of the contactor. The fuses should be appropriately sized for the system.

CAUTION & WARNING: Short circuiting of the split charge cabling without fuses installed may lead to fire.

6.2 Contactor Coil Wiring

Wire the contactor exactly as shown below:

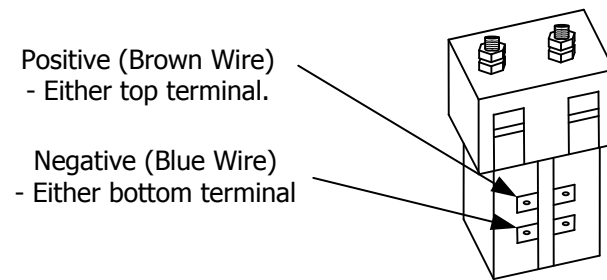

CAUTION: Incorrect wiring of the contactor will burn a track on the SmartBank Lite PCB and render the unit un-operational. This is not covered under warranty. The top connector tabs are connected together, therefore, wiring the positive and negative to the top two (or bottom two) terminals will cause a direct short circuit across the PCB.

7.0 Wiring Diagram

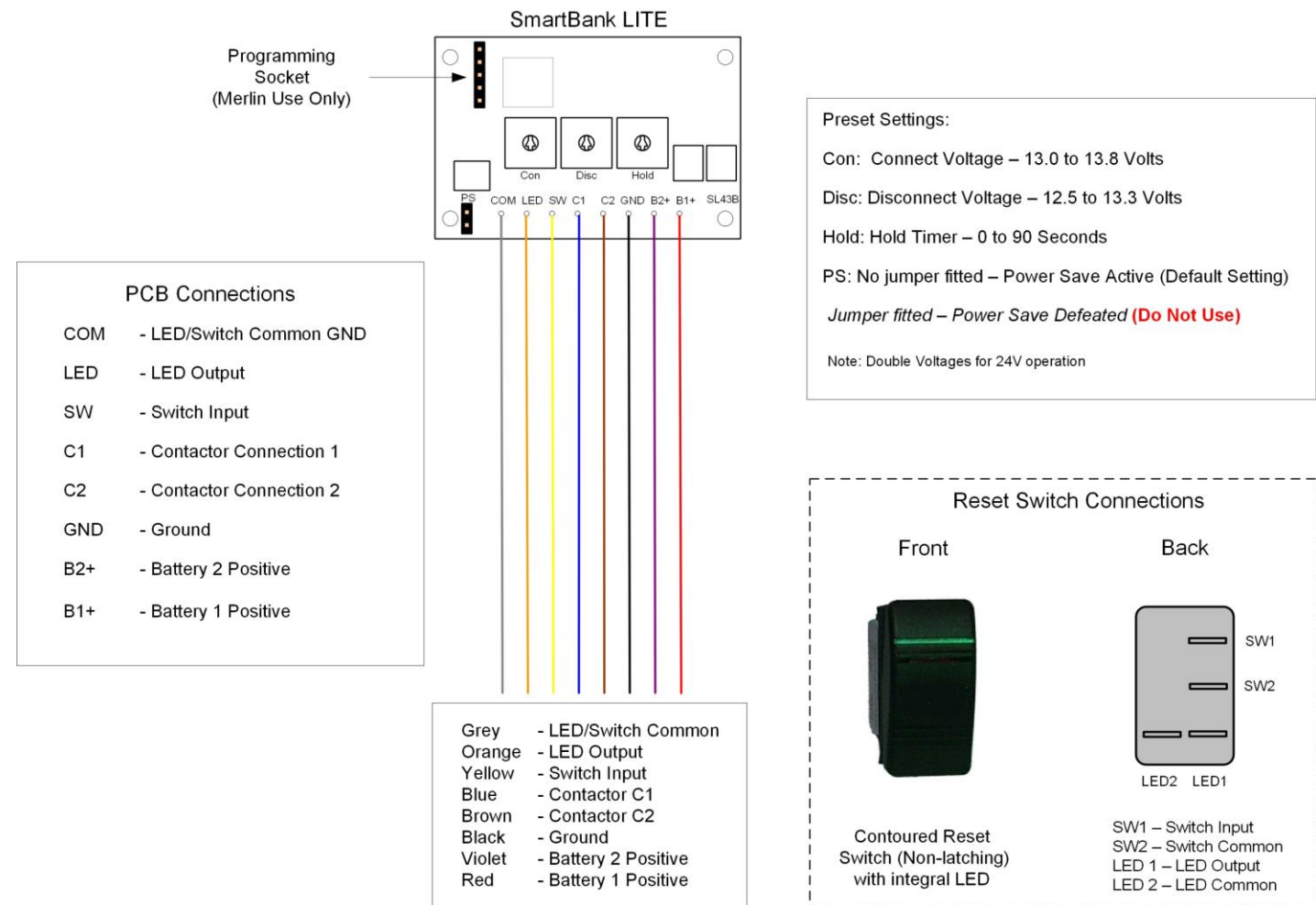

WARNING! Ensure that engine cannot be started if working in its vicinity. Ensure that the battery positive (+) is disconnected during installation. Reconnect the battery positive (+) once installation is complete.

8.0 Adjusting Settings

Adjustment of settings is achieved using trim pots and links on the main PCB. To access the PCB, remove the 4 screws in the front of the cover.

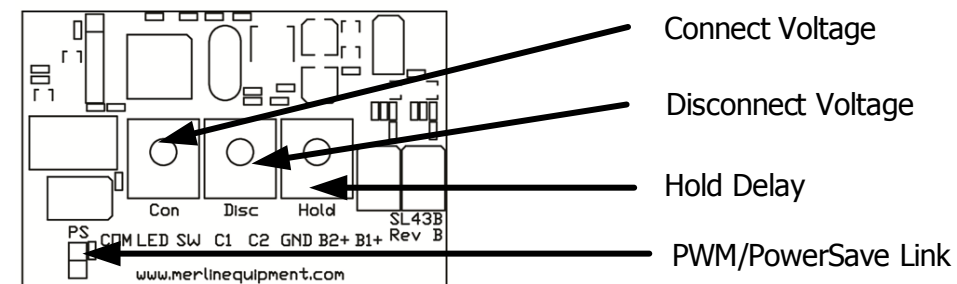

"Con" is Connect Voltage, "Disc" is Disconnect Voltage. "Hold" for the Hold Delay timer.

The hold timer preset is 0 to 90 seconds. Connect V range is 13.0 to 13.8 volts. Disconnect V range is 12.5 to 13.3 volts. (Double all voltages for 24 volt operation)

SmartBank Lite will not allow cross over of the voltages. So if you (try to) set the connect voltage lower than the disconnect voltage, it will ignore you and force the disconnect voltage to match the connect voltage.

The PowerSave/PWM link activates/deactivates the Pulse Width Modulation control for the contactor. With the link in place (over both contacts), PWM control is de-activated. With the link removed, PWM is active.

NOTE: PWM control may cause a slight high-pitch buzz or whine of the contactor. This is normal.

9.0 12/24V Operation

The SmartBank Lite CPU automatically switches between 12 or 24V operation. However, the contactors are specific to 12 or 24V. Please ensure that you have the correct contactor.

CAUTION: Using a 12V contactor on a 24V system or vice versa will cause damage to the SmartBank Lite and/or contactor.

13.0 Warranty

Merlin Equipment Limited T/a Merlin Power Systems warrants this product free from manufacturing defect for 2 years from the confirmed date of purchase.

Merlin Power Systems will repair or replace faulty product during this period at its sole discretion subject to the failure not being a result or caused by any of the following conditions: 1. Reverse polarity, connection to the incorrect voltage or reverse contactor polarity. 2. Damage caused by incorrect installation that may include (but is not limited to): Incorrect wiring, incorrect sized wiring, Ingress of water, salt, vapour, corrosive gases, diesel, petrol or other distillates of oil. 3. Physical damage/abuse. 4. Damage caused by third party equipment or systems, fire, flood, lightning and other atmospheric phenomena. This warranty expressly excludes all consequential costs including (but not limited to): Loss of use, loss of reputation, cost of installation/engineers time, cost of return freight, any banking charge etc.

To Claim Warranty please contact your Dealer. To return goods directly to Merlin, please click on the warranty tab on www.merlinequipment.com and follow on screen instructions. Merlin Equipment accepts no liability for goods returned without Returns Authorisation.

Merlin Equipment Ltd & Merlin Power Systems accepts no liability for loss, injury of damage caused by installing or fitting this equipment. If you do not accept this no liability cause, do not install the equipment. Installing it constitutes acceptance of these terms. Please ensure that the goods are suitable and appropriate for the installation. Full technical details, manuals and expert help is available from Merlin Power Systems.

Please note that this warranty, exceptions and terms do not infringe your statutory rights that may vary from country to country and state to state.

14.0 To Claim Warranty

First, please call the dealer where the unit was purchased. Alternatively, contact Merlin on +44 (0) 1202 697979 for technical support. The majority of problems can be diagnosed and rectified during a short phone call. If the SmartBank Lite requires warranty service, please log on to www.merlinequipment.com and click on Warranty on the top right hand corner.

IMPORTANT: Merlin Equipment does not accept nor accepts any responsibility for goods that are returned without following the on-line warranty procedures. The warranty procedure not only allows you to register and complete the necessary documentation but also allows you to check when warranty goods are received and their repair/replacement status.

Copyright 2013 Merlin Equipment Limited T/A Merlin Power Systems. All Rights Reserved. This publication or parts thereof may not be reproduced in any form, by any method, for any purpose. For conditions of use and permission to use this manual for publication in other than the English language, contact Merlin Equipment Limited. MERLIN EQUIPMENT LTD MAKES NO WARRANTY, EITHER EXPRESSED OR IMPLIED, INCLUDING BUT NOT LIMITED TO ANY IMPLIED WARRANTIES OF MERCHANTABILITY OR FITNESS FOR A PARTICULAR PURPOSE, REGARDING THESE MERLIN PRODUCTS AND MAKES SUCH MERLIN PRODUCTS AVAILABLE SOLELY ON AN "AS IS" BASIS. IN NO EVENT SHALL MERLIN EQUIPMENT LTD BE LIABLE TO ANYONE FOR SPECIAL, COLLATERAL, INCIDENTAL, OR CONSEQUENTIAL DAMAGES IN CONNECTION WITH OR ARISING OUT OF PURCHASE OR USE OF THESE MERLIN PRODUCTS. THE SOLE AND EXCLUSIVE LIABILITY TO MERLIN EQUIPMENT LTD., REGARDLESS OF THE FORM OF ACTION, SHALL NOT EXCEED THE PURCHASE PRICE OF THE MERLIN PRODUCTS DESCRIBED HERE IN. Merlin Equipment Limited reserves the right to revise and improve its products as it sees fit. This publication describes the state of this product at the time of its publication and may not reflect the product at all times in the future.

Installation of the product supplied with this manual constitutes full acceptance of these terms. If you do not agree to them, return the product, unused to Merlin Equipment Limited for a full refund.