

Inverter Combi Fact Sheet

The Convenience Of Combined Inverter & Charger Power

By combining inverter & charger functions plus automatic switching, a combi simplifies installation and cabling while saving considerable weight and cost.

When 230V mains power is available, the Combi will charge your battery bank with a powerful 4 stage smart battery charge. At the same time, 230V AC power is switched through the unit to feed your onboard appliances. As soon as power is removed, the combi automatically switches to inverter mode. This happens quickly enough to keep the clocks on microwaves and even most computers up and running (rather like a UPS system).

Merlin's Combi Inverter/Chargers provide a pure Sinewave AC output which is better regulated than normal grid power. This translates into interference free operation of audio visual equipment and cool running of devices that contain electric motors (washers, tools and microwaves).

AC System Considerations

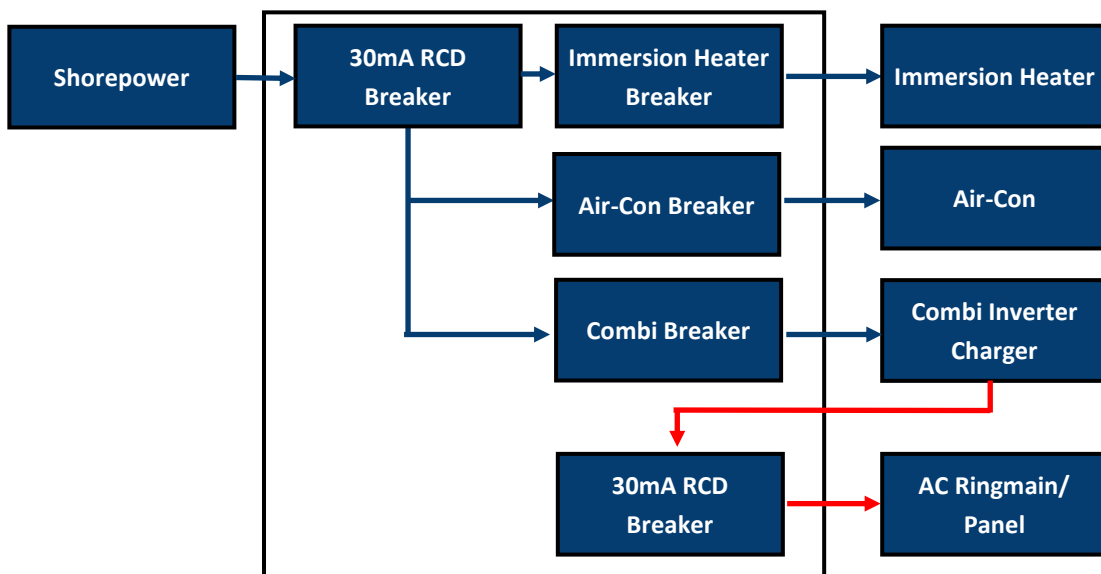

The above system works as follows: AC shore power is fed to a 16 amp 30mA RCD (Residual Current Circuit Breaker) for earth leakage protection. This in turn feeds three separate circuit breakers – one each for the immersion heater, air-conditioning and input to the combi inverter/charger. The feeds to these are shown by blue lines and are powered up only when the vehicle/boat is hooked up to 230V mains. The Combi will automatically switch between external AC power and it's own internal inverter. The output from the Combi is then run to a second 16A 30mA RCD which in turn feeds the vehicle/boat's ring main or main AC distribution panel.

When external mains is available, the Combi acts as a charger and feeds the external power through to the AC ringmain/panel (at the same time, the shore power only loads are also active). When shore power is disconnected, the shore power only loads will not operate, while those connected through the red lines will (from inverter). This system is totally automatic and requires no intervention by the user.